

REV.	ECN. NO.	APPD.

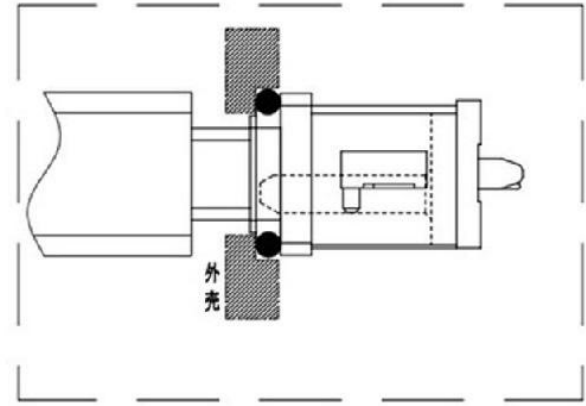
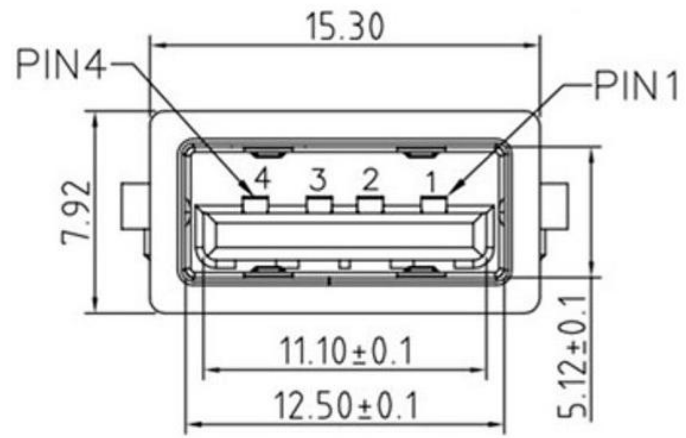
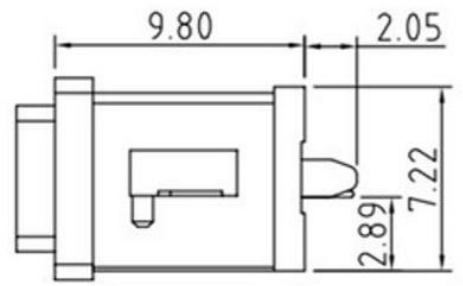
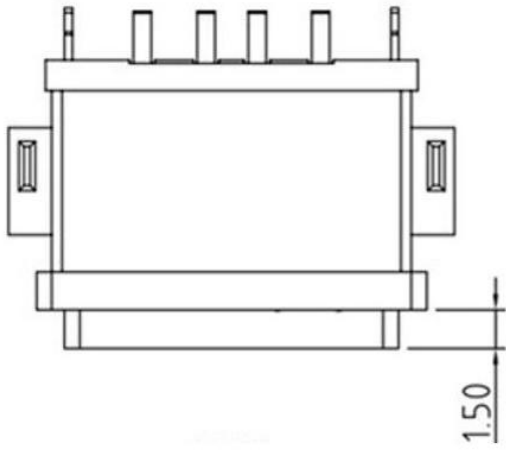

NOTES:
SPECIFICATION:

1. CURRENT RATING: 3.0A MAX
2. DIELECTRIC WITHSTAND VOLTAGE: 100VAC
3. TEMPERATURE RANGE: -30 °C ~ 85 °C
4. CONTACT RESISTANCE: 40 MILLIONHM MAX
5. INSULATION RESISTANCE: 100 MEGOHMS MIN.
6. INSERTION FORCE :8N~35N
7. UNMATING FORCE: 8N~35N
8. DURABILITY:1500 CYCLES

3	Shell	1	SUS 301 1/4H	
3	PLASTIC Shell	1	PA9T&LCP (G.F30%)	
2	Contact	4	BRASS C2680-EH Au/Ni Plating T=0.25mm	
1	Housing	1	PA10T (G.F30%)	
ITEM	PART NAME	Q'TY	FINISH	NOTE

X.	±0.50	X.*	±2*	UNITS	mm
.X	±0.30	.X.*	±1*		
.XX	±0.10	.XX.*	±0.5*	MAT'L	/
.XXX	±0.05				

THESE DRAWINGS AND SPECIFICATIONS ARE THE PROPERTY OF E-ZONE ELECTRONIC TECHNOLOGY CO.,LTD.AND SHALL NOT BE REPRODUCED, COPIED OR USED IN ANY MANNER WITHOUT THE PRIOR WRITTEN CONSENT OF E-ZONE ELECTRONIC TECHNOLOGY CO., LTD.

東莞市高迪電子有限公司 DONGGUANGAODI ELECTRONICS CO.,LTD.		PART NO.	TITLE: IP68
FINISH		APPD: RADDM	DWG NO: USB connector
Q'TY		CHKD: MARK	SCALE SHEET REV.
		DR: JANE CHOU 2019/07/11	1/1 1/2 A2

由Autodesk 教育版产品制作

由Autodesk 教育版产品制作