

CAD FILE:

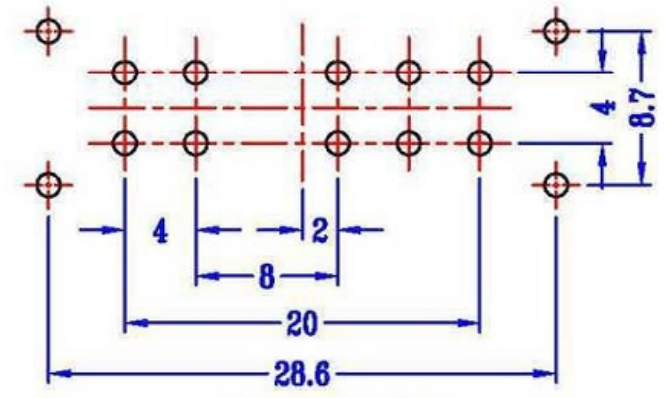

P.C.B LAYOUT  
BOTTOM VIEW

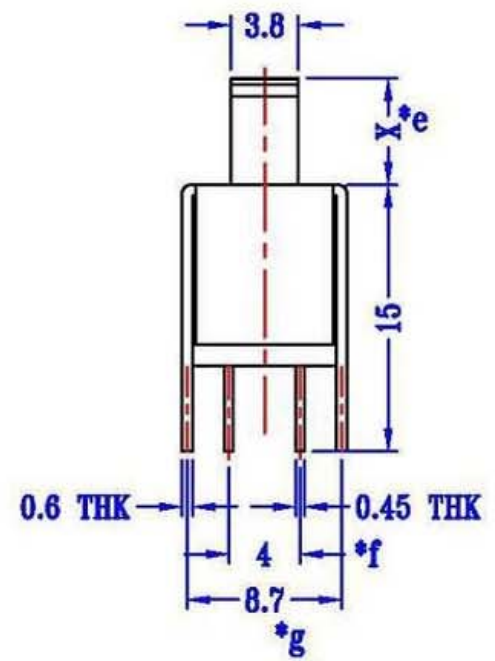
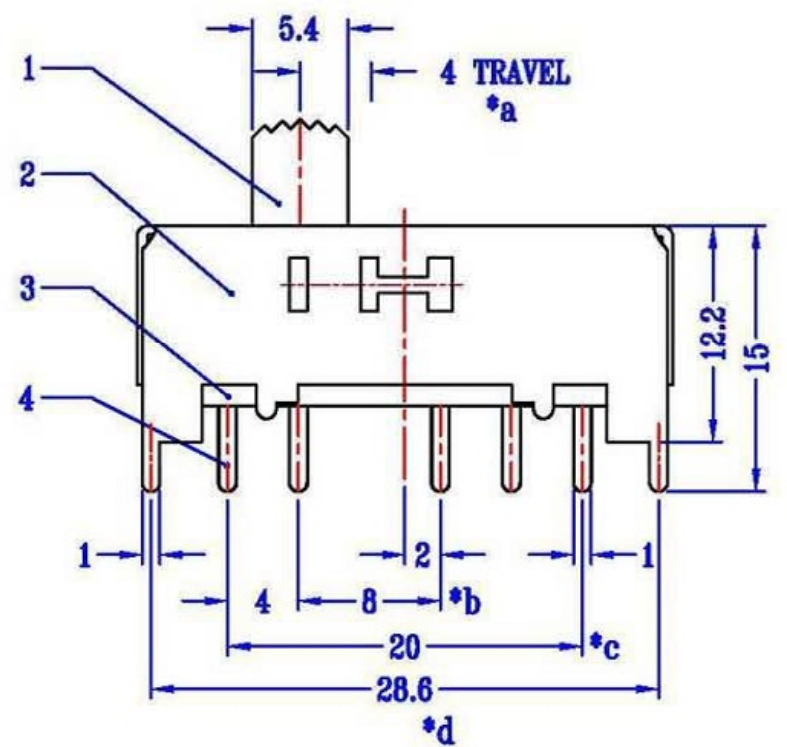
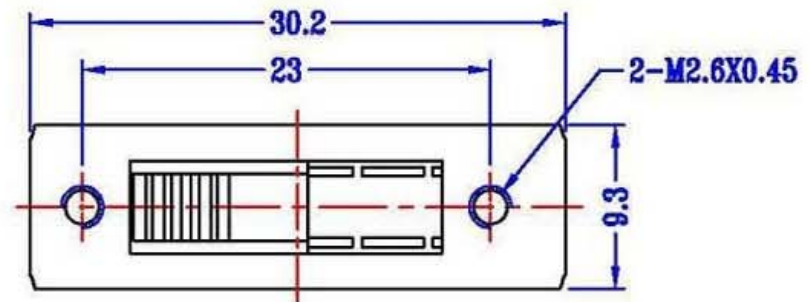
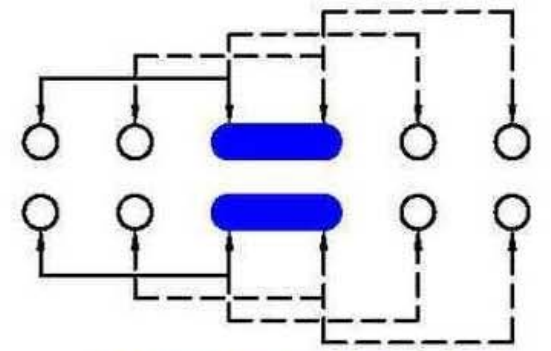

SCHEMATIC (SHORTING)

- 拨动开关立式技术参数:
1. 额定负荷: DC 30V 50V 0.3A 0.5A
  2. 接触阻抗:  $\leq 50m\Omega$
  3. 绝缘阻抗:  $\geq 100m\Omega$  DC500V
  4. 耐焊温度:  $250 \pm 5^\circ$  5s
  5. 使用寿命: 10,000 cycles
  6. 使用温度:  $-25^\circ\text{C}$  to  $80^\circ\text{C}$
  7. 使用湿度:  $\leq 85\%$  RH
  8. 操作力: 160gf 256gf 300gf 可定制
  9. 手柄长度: 2mm-10mm 可定制

NO.	PARTS	MATERIALS	Q'TY	FINISH	TOLERANCE		DATE		DESCRIPTIONS OF REVISION		APPD.			
8					UNLESS SPECIFIED									
7	STEEL BALL	STEEL	1	NATURAL	WITHIN		A	2012-10-28	初版					
6	SPRING	STEEL WIRE	1	NATURAL	OVER		ISSUE	DATE						
5	CONTACT CLIP	PBS STRIP	2	Ag PLATED	TITLE : VERTICAL SLIDE SWITCH			UNIT : mm	DRWG NO.:					
4	TERMINAL	BRASS STRIP	8	Ag PLATED	MODEL:			SCALE: 3:1	DWN.		2012-10-28			
3	BASE	PHENOLIC RESIN	1	NATURAL	<b>东莞市高迪电子有限公司</b>							CHK'D		
2	FRAME	STEEL STRIP	1	Ni PLATED								APPD.		2012-10-28
1	KNOB	POM	1	BLACK										