

P.C.B LAND PATTERN

SPECIFICATIONS

Rating	0.3A 4V DC
Insulation Resistance	50MΩ Min.
Dielectric Withstanding Voltage	AC 250 V(50Hz)1min
Contact Resistance	100mΩ Max.
Operating Force	190 ± 50gf
Operating Life	10,000 cycles

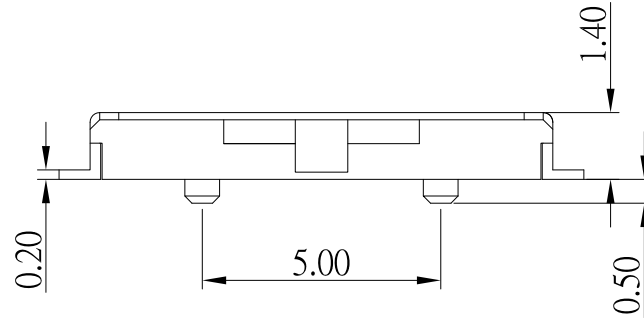
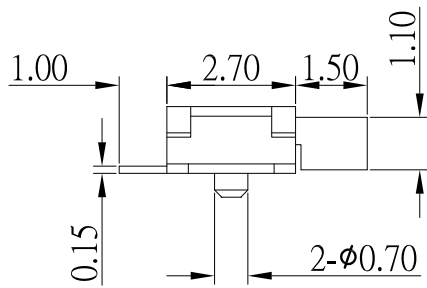

NO.	DESCRIPTION	QTY	MATERIAL	PLATING
E	TERMINAL	4	PHOSPHOR BRONZE	Ag plated
D	CLIP	2	SUS	Ag plated
C	COVER	1	PHOSPHOR BRONZE	
B	CASE	1	LCP	Black
A	SLIDER	1	PA46	Black



东莞市高迪电子有限公司
Dong Guan KDRR Electronic Switch Jack Co., Ltd.

TOLERANCE UNLESS OTHERWISE STATED:

Up to 5 ±0.2
Above 5 ~ 15 ±0.3
Above 15 ~ 30 ±0.4
Above 30 ~ 50 ±0.5
Angle ±0.3°

3RD. ANGEL'S



UNITS

MM

DRAWN BY: Jack Lu
CHECKED BY: Jacky Chen
APPROVED BY: Tony Kao

DATE: 02/18/14
DATE: 02/18/14
DATE: 02/18/14

MAT'L
FINISH
SCALE: 1 : 1
SHEET NO. 1 of 1

TITLE: SWITCH
MODLE: SLIDE SWITCH
DWG NO.: SS-C00AP-B-S246
PART NO.: SS-C00AP-B-S246

SIZE: A4
VER: R

ITEM NO.	DESCRIPTION	DRAWN	DATE